

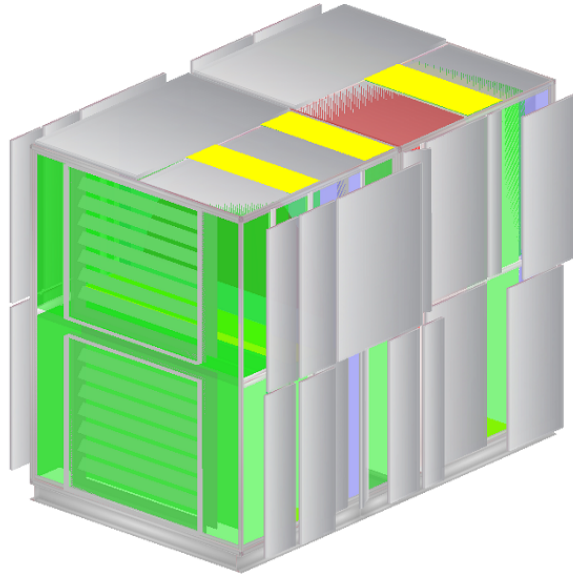

Installation, Operation and Maintenance Manual



Unit Size: MAX37
Order Number:
Customer Name:
Drawn By: DR

Site Reference:
Unit Reference:
Drawing Number: M4XA837039
Part Number: MAX37/A/SW/S

Contents

1	General Information
2	Inlet
3	Panel Filter
4	Rotary Heat Exchanger
5	Plug Fan
6	Low Pressure Hot Water Coil
7	Warranty
8	Declaration of Conformity



max Air Handling Unit
bespoke

Installation, Operation and Maintenance Manual

General information

Important  This manual and all other relevant accompanying documentation must be read in full before Installation, Operation or Maintenance of the unit supplied.

For individual unit components please refer to the relevant accompanying O&M sections.

Only authorised, qualified personnel should undertake work on this unit.

Please ensure this document and all other relevant documentation is passed on to the end user. These manual form an integral part of the product and should be kept for the working life of the product.

Additional copies of this and supporting documents are available by contacting VES Andover Ltd. or by visiting www.ves.co.uk and following the 'Download O&M's link'

The following symbols used within this document refer to, potential dangers, advice for safe operation, or important points of reference.

Warning  Indicates hazards associated with electric current and high voltages.

Caution  Indicates hazards that require safety advice for personal and/or potential unit/property damage.

Important  Indicates important information.

Introduction

The MAX series is a range of direct or belt driven air handling units. Suitable for plantroom or external locations, each unit will have been supplied with either, no pre-wiring, a pre-wired external isolator, or with a fitted control panel; as specified at the time of order. The standard operating temperature of these units is -20°C to +35°C.

For further technical details regarding dimensions and weights, contact VES Andover Ltd. on **08448 15 60 60**, quoting the sales order (SO) number and the unit type as found on the unit name plate.



Installation, Operation and Maintenance Manual

General information

Nomenclature

Part number coding

Point description	Point variants	Details
1 Product	MAX	MAX Air Handling Units
2 Unit Size	01....50	Sequential see unit outline for details
3 Construction	/A /B /C /D	25mm Tubular Frame 50mm Tubular Frame 25mm Customised 50mm Customised
4 Configuration	/P /W /FP /FW /SP /SW	Plantroom Weatherproof Flat Plantroom Flat Weatherproof Stacked Plantroom Stacked Weatherproof
5 Special	/S	Special (all Max units are classed a special)

Typical Example

MAX30/B/P/S

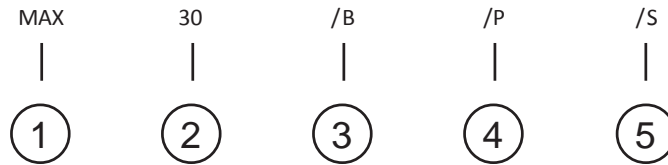

Receipt of Goods & Handling

Immediately upon receipt of goods, check for possible damage in transit, paying particular attention to fan impellers, motor, flexible connections, coil connections and unit casing. Prior to installation, please check to ensure alignment and smooth rotation of the impeller after transit. Also check to ensure that any ancillary items are included. These will normally be supplied fitted or, in the case of small items, taped to the unit.

In the event of any damage having occurred or if an item is found to be missing, it is essential to inform VES Andover Ltd. within **7 working days** of delivery, quoting the sales order number and the unit type, as found on the unit name plate.

After this period, VES Andover Ltd. will be unable to accept any claim for damaged or missing goods.



max Air Handling Unit
bespoke

Installation, Operation and Maintenance Manual

General information

Installation

The entire system must be considered for safety purposes and it is the responsibility of the installer to ensure that all of the equipment is installed in compliance with the manufacturer's recommendations, with due regard to the current **HEALTH AND SAFETY AT WORK ACT** and conforms to all the relevant statutory regulations.

Where a unit is installed so that a failure of components could result in injury to personnel, precautions should be taken to prevent any such injury. If the unit is installed where there is a reasonable possibility of persons or objects coming into contact with the impeller whilst operational, a guard should be fitted or steps taken to prevent this.

It is the installer's responsibility to ensure that access panels are not obstructed in any way and safe working access to the unit for maintenance must be provided in accordance with Health and Safety Building Regulations. For confirmation of required access please see the appropriate unit outline drawing; note that some access doors are hinged.

For optimum unit performance, careful consideration must be paid to the location of the unit in relation to the ductwork and associated items; placing the unit directly adjacent to a bend in ductwork will impede airflow and reduce performance.

Consideration must also be given by the installer for adequate illumination of the unit location in order for safe maintenance. Further consideration should be given to the unit's position so that the unit can be adequately secured into place, this is especially important with external mounting as the wind and elements may effect the overall stability of the unit.

Sectional (tubular framed) units should be assembled using self adhesive rubber tape or foam at the joins prior to assembly so as to prevent air leakage; replace with similar if damaged.

Only parts specifically designed for the unit supplied and recommended by VES Andover Ltd. should be used, non genuine parts, or parts from non original sources are not guaranteed to meet load and safety requirements set out by the original manufacturer. Such parts are not approved by VES Andover Ltd. and the use of such parts may effect the terms of any warranty held with VES Andover Ltd.

Warning  Faults detected within any electrical equipment must be rectified as soon as possible. If faults are not resolved the unit becomes potentially hazardous, the unit should not be operated when faulty.

Installation, Operation and Maintenance Manual

General information

Installation Continued Lifting Details

The weight of each section of the unit is specified on the outline drawing and the total unit weight will be displayed on the unit inspection label.

Lifting of a Max unit, using a fork lift truck, with forks extended under the unit. Ensure the whole unit is supported by the full length of the forks under the channel base. As shown Fig. ①.

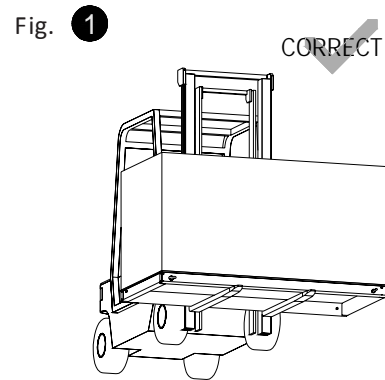

Lifting of a large Max unit, using a fork lift truck, with forks extended under the unit. Ensure the unit is supported by the forks under a minimum of 2 of the channels, depending upon the size, weight and number of channels on the unit. As shown Fig. ②.

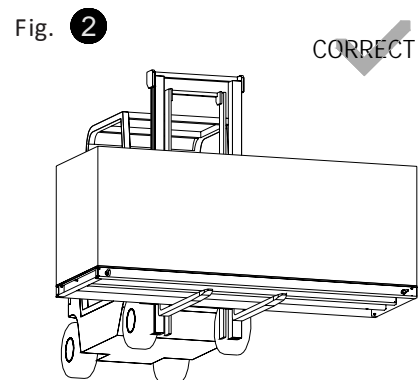

Caution The units centre of gravity may be offset from the centre of the unit.

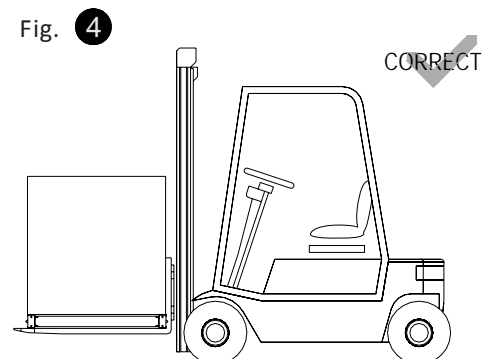
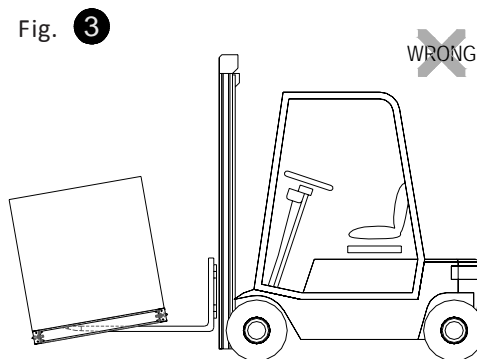

Lifting of a Max unit, using a fork lift truck, with forks extended under the unit. Ensure that forks extend all the way under the channel base, as shown Fig. ④. Lifting the unit, as shown in Fig. ③ will lead to damage to the under side of the unit case work.

Installation, Operation and Maintenance Manual

General information

Installation Continued Lifting Details

When moving the unit, handle with care and in such a manner as to avoid damaging the external finish as this may reduce the ability to resist corrosion.

Units are to be rigged and lifted using the spreaders, taking into account the weight of the unit and lifting gear should be arranged so as not to bear on the casework.

As shown Fig. 5.

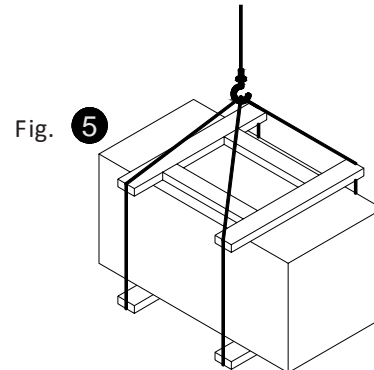

Important If lifting lugs have been supplied or fitted, it is recommended that they are used when lifting the unit. Some Max units are supplied in sections. It is important to ensure that all sections are joined together securely prior to, or during, positioning and installation.

Caution Handles, lids, housings and coil connections must not be used as lifting points.

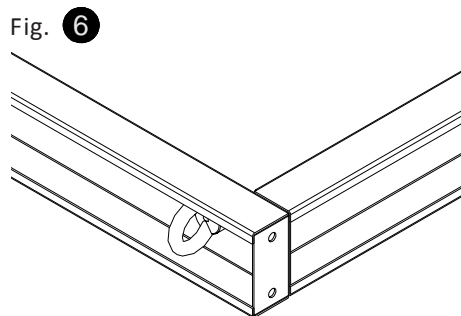

Lifting lugs, attached to channel base.

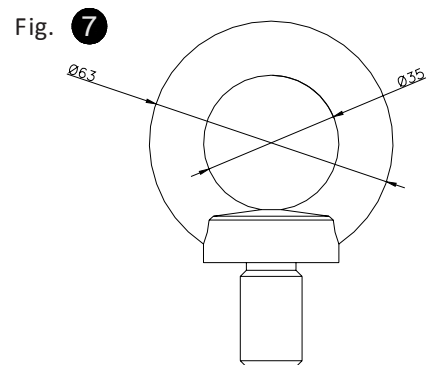

16mm DIN580 Eyebolt, dimensions.

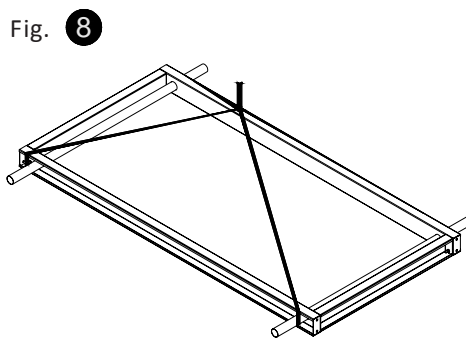

Lifting bar, through a channel base.

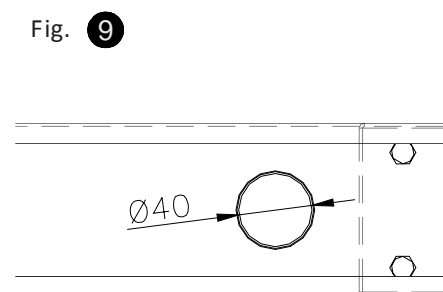

Hole for lifting bar, dimensions.

Installation, Operation and Maintenance Manual

General information

Installation Continued Section joins

Units supplied in one section as standard will be factory assembled with the appropriate fixings. Larger units may be supplied in multiple sections and some site assembly will be required. Units are joined internally or externally using one or two of the methods shown below. These methods depend upon the unit size and tube size. Refer to your outline drawing for confirmation of, the unit size; the construction, the number of sections, the section weights and the order in which the sections go together, listed 1,2,3,4 etc.

For accurate unit alignment, all sections need to be correctly lined up and adjoined, using self adhesive butyl tape or foam at the joins prior to assembly, so as to prevent air leakage: replace with similar if damaged.

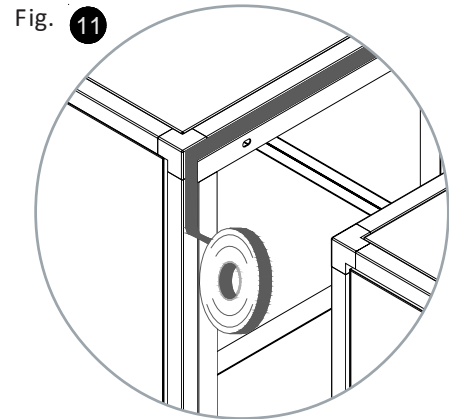
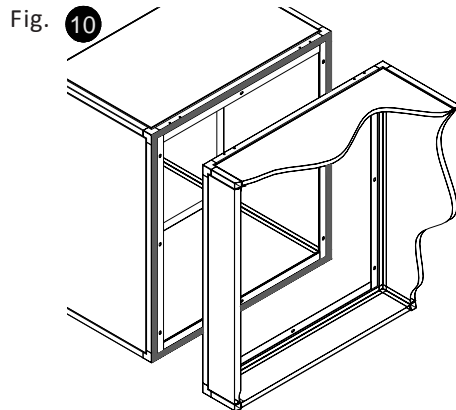

Positioning of butyl tape to section joins

Sections should then be bolted together using the fixings provided with the unit, ensuring that sections are in the correct order and handing, for confirmation of details please see the appropriate unit outline drawing.

Important

When joining unit sections ensure that base is on flat, level surface. Joining on an uneven surface will result in stress being put on the joints and fixings. Do not use the fixings to pull the sections together, as this will cause damage to the casework.

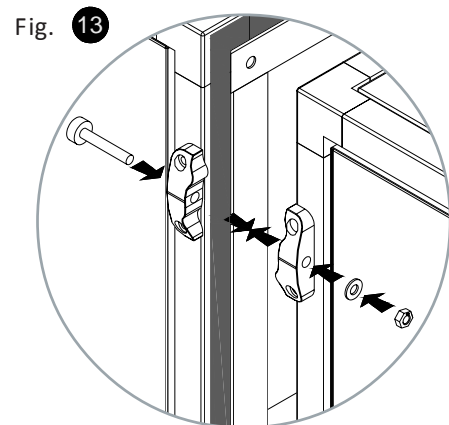
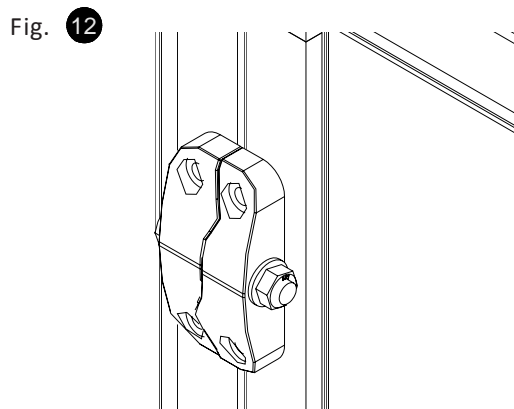

25 and 50mm frame external jointing method, pre drilled casework to suit. Use M8 fixings as supplied secured within the unit sections. Ensure fixing are evenly tightened to prevent damage to unit casework.

max Air Handling Unit

Installation, Operation and Maintenance Manual

General information

Installation Continued Section joins

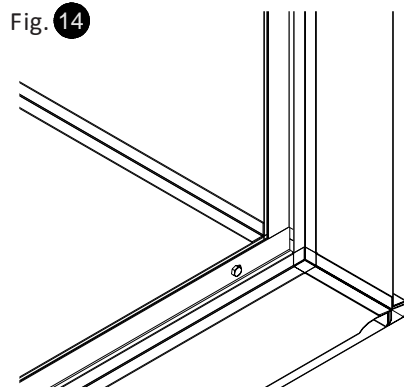

Fig. 14

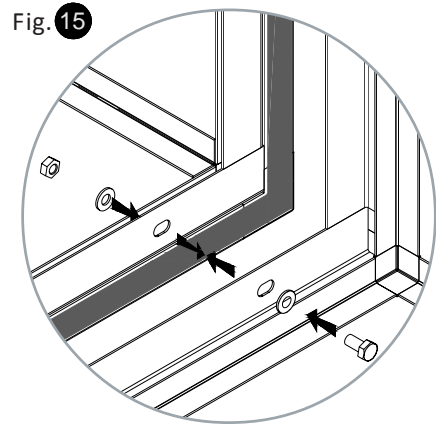

Fig. 15

25mm frame internal joining method, pre drilled internal flange. Use M8 fixings as supplied secured within the unit sections. Ensure sections fixings are evenly tightened to prevent damage to the unit casework.

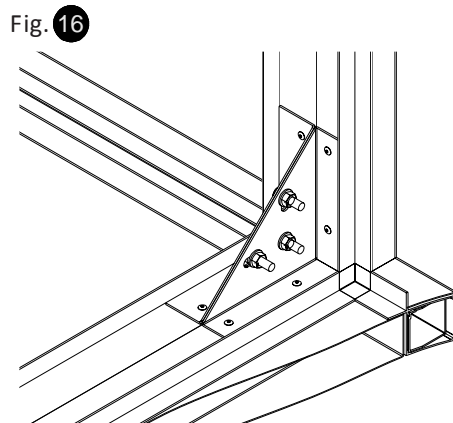

Fig. 16

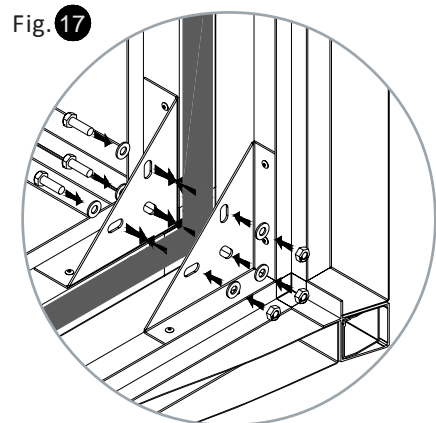

Fig. 17

50mm frame internal joining method, fitted internal gusset. Use M8 fixings as supplied secured within the unit sections. Ensure section fixings are evenly tightened to prevent damage to the unit casework.

If the unit is sectional, then the base for the unit will be supplied in sections to fit.

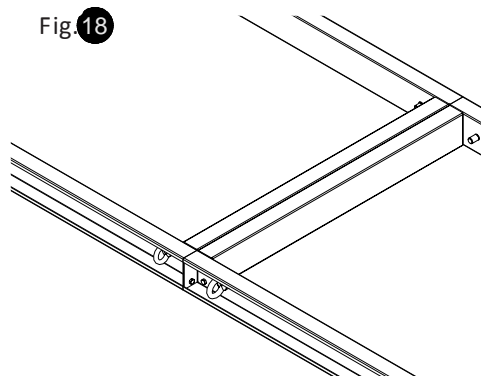

Fig. 18

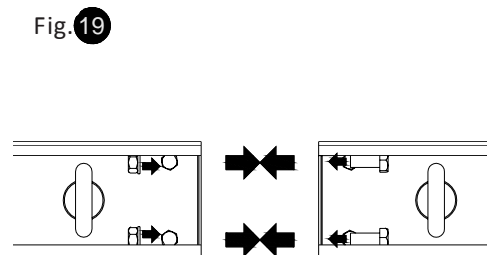

Fig. 19

Joining channel base sections. Use M8 fixings as supplied secured with the unit.

max[®] Air Handling Unit

Installation, Operation and Maintenance Manual

General information

Installation Continued

Section joins

Sectional units can be provided in many orientations.

Always ensure that all section joins are sealed with silicone or mastic to help prevent air leakage and to protect the unit against the elements.

Fig. 20

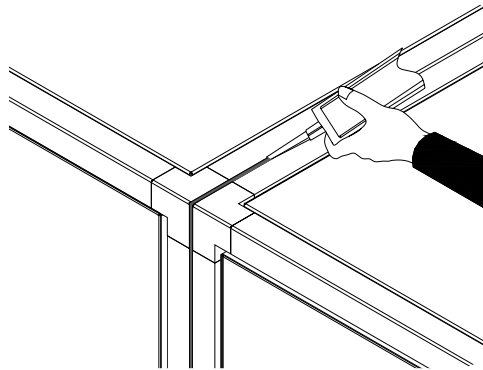

Sealing unit sections together using silicone or mastic.

Fig. 21

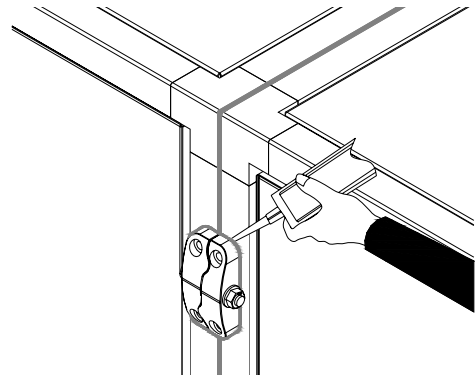

Sealing around the external joining bracket.

Lids positioned next to a taller section of the unit, should also be sealed with mastic along the join before and after fitting, as shown Fig. 22 Fig. 23 .

Fig. 22

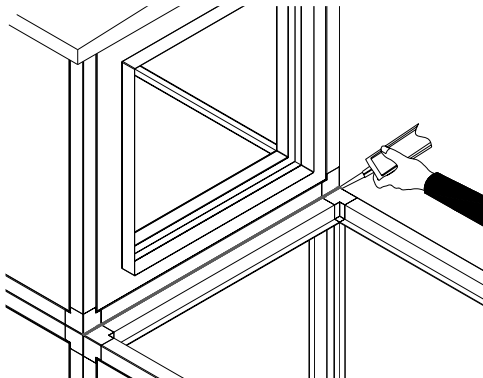
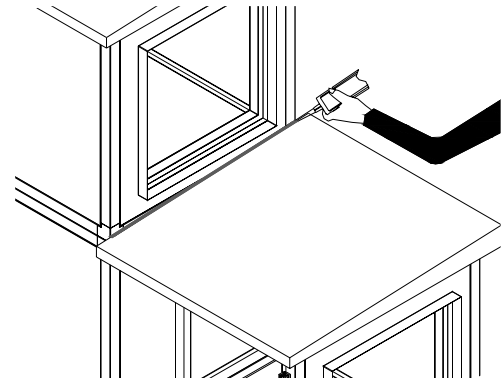

Fig. 23



Sealing a unit lid when positioned next to a taller unit section.



Installation, Operation and Maintenance Manual

General information

Installation Continued Mounting

Max units are suitable for floor, foundation, wall bracket or drop rod ceiling mounting, as specified at the time of order. Units are designed to be mounted horizontally, even if the air flow direction through the unit is different. Max units are supplied with a base suitable for the mounting method specified.

For alternative mounting, please refer to VES Andover Ltd. Technical Department for further information.

Important  When mounting a unit, ensure that the load is evenly spread and that all feet, or bases are used properly. It is important that the unit is level to ensure it operates correctly.

Fig. 24



Channel base detail

Fig. 25

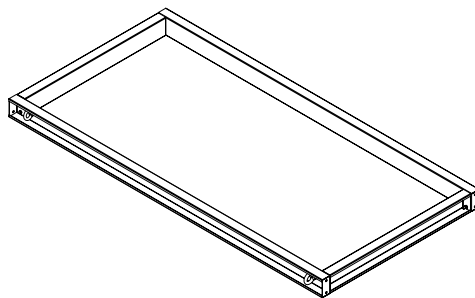
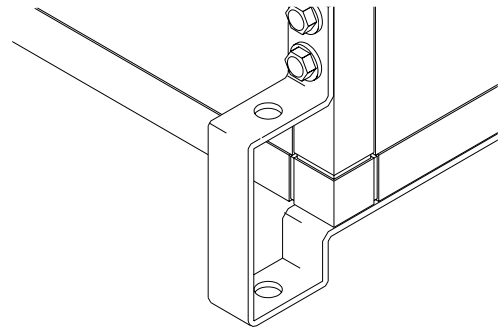

Feet detail

Caution  Units should only be supported using the support feet or channel base as provided by VES Andover Ltd. with the unit. Contact VES Andover Ltd. before attempting to support the unit using alternative methods.
 Only experienced fitters should undertake this work.
 Take necessary precautions when working in elevated positions.

Drain pan Trap

Where a drain pan is fitted, please refer to trapping detail manual: 'VES Ref:ID665' Drain Trap Installation'. Consideration should be given to the height required for the trap to function correctly and that the unit may need additional base support in order to accommodate this adequately.

Duct Installation

Where provided, flanges and spigots should be used solely as a means of ductwork connection and not used to support the ductwork. For confirmation of the duct connections provided refer to the outline drawing.



max Air Handling Unit
bespoke

Installation, Operation and Maintenance Manual

General information

Maintenance Continued

Important  For individual component maintenance requirements please refer to the relevant section of this O&M.

Recommended Checks To keep the unit in good working order the following maintenance routine is recommended.

Three Monthly Checks The belt drive should be thoroughly checked. If belts are found to be loose or worn, retighten or replace as necessary. Refer to relevant accompanying documentation for details and recommended tension.

Filters should be inspected regularly. If they are found to be heavily soiled or damaged they should be replaced immediately.

The general operation of the unit should be inspected, particularly for noise from bearings, motors and fans. An irregular noise could signify that unit failure is imminent.

Six Monthly Checks As above, plus:
Check for dust build-up in the system, especially around the impeller. Remove dust if necessary. Failure to do this periodically could lead to a loss of performance or cause the fan to become out of balance, ultimately leading to bearing failure.

Coils should be inspected to ascertain if any foreign matter has accumulated between the fins and that the coil connections are free from any leaks.

Should any matter be found, the coils should be cleaned using a soft brush and mild solution of commercial detergent. If heavily contaminated, a steam lance may be used.

Important  Care should be taken so as not to damage or distort the fins during this cleaning process.

Periodically inspect heat exchange matrix for any debris, dust or dirt build up. Frequent contamination might be as a result of poor filtration and should be investigated.

Caution  Under NO circumstances should the heat exchanger be steam cleaned.

Ensure the drain pan and the drain connection is free from debris ensuring any condensate produced can freely drain away.

Annual Checks Max units are supplied with either unpainted galvanized sheet steel or powder coat paint finishes. Check all painted items to ensure that they have not deteriorated. Repaint as necessary. Paint can be supplied upon request. Checks should be carried out for missing fasteners.

In general, this series of units require little maintenance. In the unlikely event of component failure, spares are available from VES Andover Ltd.



max Air Handling Unit
bespoke

Installation, Operation and Maintenance Manual

General information

Maintenance

Continued

Important  Before attempting to carry out any work on our units, all accompanying documentation including warning labels on the unit must be referenced. Should it be necessary to remove any components ensure that these are secured into position once reinstalled. It is critical that after any maintenance work has been conducted that all components removed/replaced be refitted correctly by a competent engineer.

Warning  Before attempting to carry out any maintenance, investigative or repair work on our units, the unit **MUST BE COMPLETELY ISOLATED** from its electrical supply. Ensure a minimum of two minutes after electrical disconnection before removing access panels. This will allow any moving parts to come to a rest. Care should also be taken when accessing external units as the wind and elements may cause moving parts to 'windmill'.
When used in conjunction with an inverter for speed control, a minimum of 5 minutes should be given to allow for the capacitors to discharge before starting work after disconnection from the power source.

Caution  Ensure the unit has been allowed to completely cool before attempting any work to the unit.

Should a full service be required it may be necessary to disassemble the unit casework to gain access to some components.

Caution  When accessing the unit ensure the access panels are handled/opened in a controlled manner so as to avoid damage to the unit or injury to personnel. This is particularly important with bottom access units.

Important  Should it be necessary to remove any slide-in components ensure that these are secured into position once reinstalled. It is critical that after any maintenance work has been conducted that all components removed/replaced be refitted correctly by a competent engineer.

Sufficient clearance should be provided to enable access to the unit casework, for confirmation of required access please refer to the appropriate outline drawing; note some access doors are hinged.



max Air Handling Unit
bespoke

Installation, Operation and Maintenance Manual

General information

Maintenance Continued

Spares & Repairs

When enquiring about, or ordering spares contact VES Andover Ltd. Spares Department, quoting the sales order (SO) number and unit type as found on the unit name plate.

Tel: 08448 15 60 60

Fax: 02380 26 12 04

WEEE Directive



At the end of their useful life the packaging and product should be disposed of via a suitable recycling centre. Do not dispose of with normal household waste. Do not burn.



PLEASE ENSURE THIS DOCUMENT IS PASSED ON TO THE END USER

We reserve the right to alter the specification without notice © VES Andover Ltd. 2012.
No part of this publication may be photocopied or otherwise reproduced without prior permission in writing of VES Andover Ltd.



max[®] Air Handling Unit

Installation, Operation and Maintenance Manual

Dampers

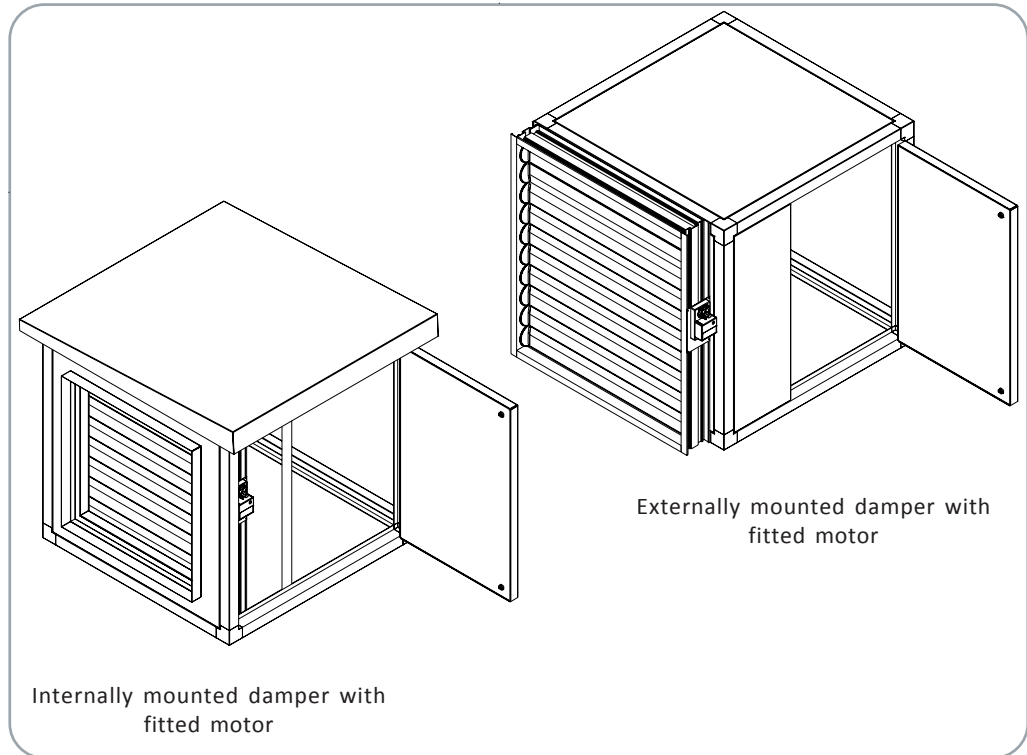

Introduction

This Max unit has been fitted with a Damper. Dampers are used to close off the air flow to the unit. Dampers are mounted internally on weatherproof options and externally on plantroom units. Dampers are supplied, with a fitted motor, suitable for motorisation by others, or with an extended shaft suitable for hand operated crank.

Receipt of Goods & Handling

Check for possible damage in transit. In the event of any damage having occurred or if an item is found to be missing, it is essential to inform VES Andover Ltd. within **7 working days** of delivery, quoting the sales order number and the unit type, as found on the unit name plate.

After this period, VES Andover Ltd. will be unable to accept any claim for damaged or missing goods.

Installation

Weatherproof units will have been supplied with access to any internally mounted dampers either left or right hand side looking in the direction of airflow. Please see order acknowledgment or outline drawing for confirmation of this handing. Should you need to alter this please consult VES Andover Ltd. as unit adjustment may invalidate your warranty.



max[®] Air Handling Unit

Installation, Operation and Maintenance Manual

Dampers

Installation Continued

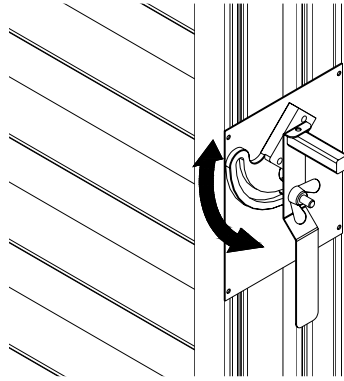

Hand operated damper

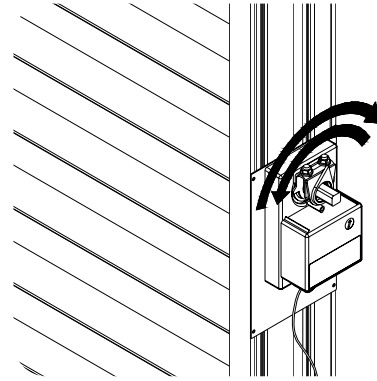

Motorised damper

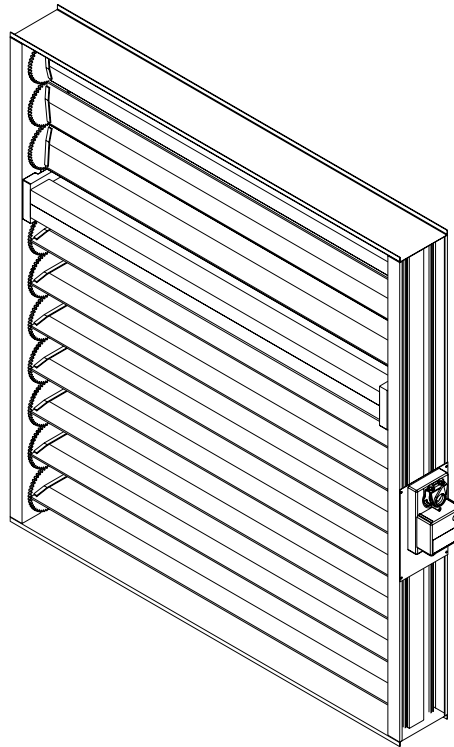

Face and Bypass damper

max Air Handling Unit

Installation, Operation and Maintenance Manual

Dampers

Installation Continued

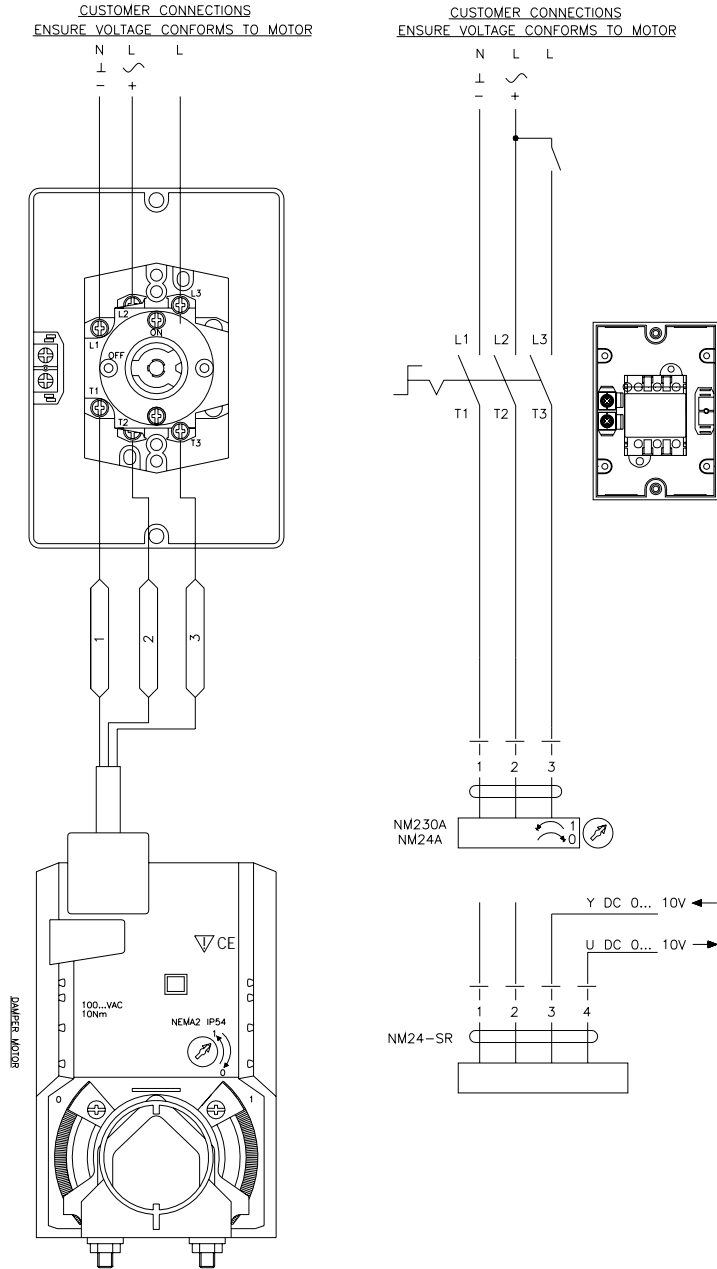

Wiring diagram for standard damper motor



max[®] Air Handling Unit
bespoke

Installation, Operation and Maintenance Manual

Dampers

Maintenance

Caution  When accessing the unit ensure the access panels are handled/opened in a controlled manner so as to avoid damage to the unit or injury to personnel. This is particularly important with bottom access units.

Recommended Checks

To keep the unit in good working order the following maintenance routine is recommended. Dampers should be inspected every six months. Failure to keep dampers clean could result in the damper becoming inoperative. Clean damper blades, cogs and frames and lubricate with PTFE aerosol or equivalent.

In general, this series of units require little maintenance. In the unlikely event of component failure, spares are available from VES Andover Ltd.

Important  Before attempting to carry out any work on our units, all accompanying documentation including warning labels on the unit must be referenced. Should it be necessary to remove any components ensure that these are secured into position once reinstalled. It is critical that after any maintenance work has been conducted that all components removed/replaced be refitted correctly by a competent engineer.

Warning  Before attempting to carry out any maintenance, investigative or repair work on our units, the unit **MUST BE COMPLETELY ISOLATED** from its electrical supply. Ensure a minimum of two minutes after electrical disconnection before removing access panels.

Caution  Ensure the unit has been allowed to completely cool before attempting any work to the unit.

Should a full service be required it may be necessary to disassemble the unit casework to gain access to some components.

Important  Should it be necessary to remove any slide-in components ensure that these are secured into position once reinstalled. It is critical that after any maintenance work has been conducted that all components removed/replaced be refitted correctly by a competent engineer.



Installation, Operation and Maintenance Manual

Dampers

Maintenance Continued

Important



Sufficient clearance should be provided to enable access to the unit casework, for confirmation of required access please refer to the appropriate outline drawing; note some access doors are hinged.

Spares & Repairs

When enquiring after or ordering spares contact VES Andover Ltd. Spares Department, quoting the sales order (SO) number and unit type as found on the unit name plate.

Tel: 08448 15 60 60

Fax: 02380 26 12 04

WEEE Directive



At the end of their useful life the packaging and product should be disposed of via a suitable recycling centre. Do not dispose of with normal household waste. Do not burn.



PLEASE ENSURE THIS DOCUMENT IS PASSED ON TO THE END USER

We reserve the right to alter the specification without notice © VES Andover Ltd. 2012.
No part of this publication may be photocopied or otherwise reproduced without prior permission in writing of VES Andover Ltd.



max Air Handling Unit
bespoke

Installation, Operation and Maintenance Manual

Panel Filters

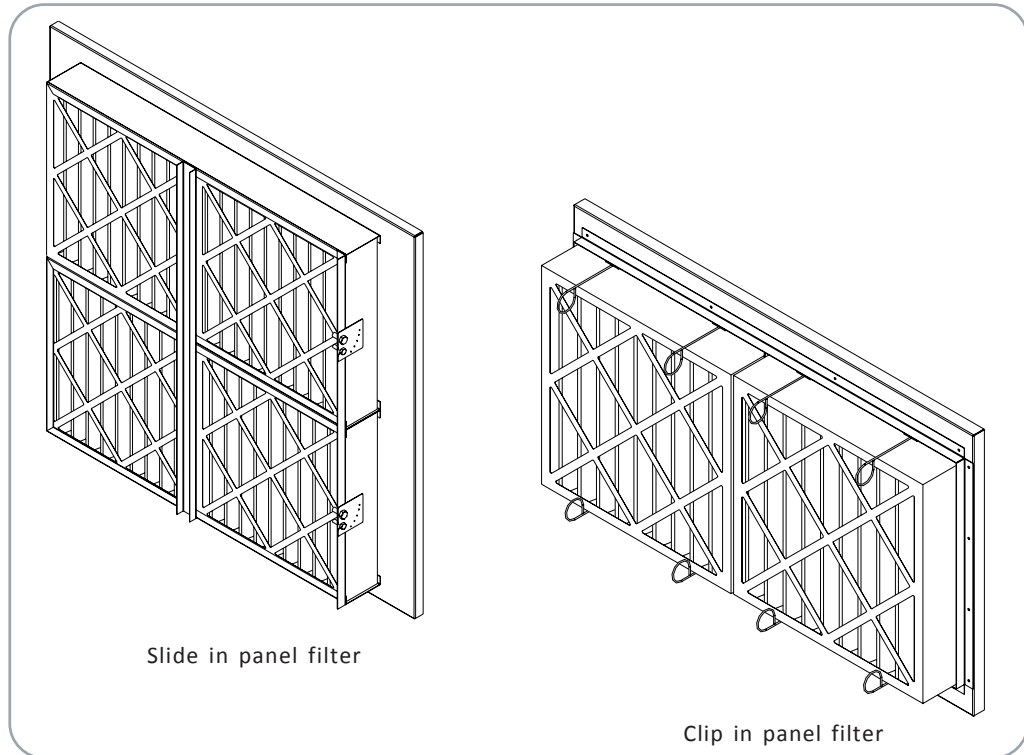

Introduction

This Max unit has been fitted with a Panel filter. Panel filters are used to take out particles such as dust etc. from the air. Panel filters are mounted in a variety of ways, slide in mounted in channels for side withdrawal, clip in front withdrawal and clip in back withdrawal. A viewing porthole may have been provided to view this section, this is an optional extra which would have been specified at the time of order.

Receipt of Goods & Handling

Check for possible damage in transit. In the event of any damage having occurred or if an item is found to be missing, it is essential to inform VES Andover Ltd. within **7 working days** of delivery, quoting the sales order number and the unit type, as found on the unit name plate.

After this period, VES Andover Ltd. will be unable to accept any claim for damaged or missing goods.

Installation

The unit will have been supplied with access to the filter, either top, bottom, left or right hand side looking in the direction of airflow. Please see order acknowledgment or outline drawing for confirmation of this configuration. Should you need to alter this please consult VES Andover Ltd. as unit adjustment may invalidate your warranty.

The flow resistance of the filter gradually increases as dust steadily accumulates over time. This causes a decrease in airflow through the filter. The filter should be changed periodically, at intervals determined by the level of dust in the air.

max Air Handling Unit

Installation, Operation and Maintenance Manual

Panel Filters

Installation Filter pressure switch

A filter pressure switch is recommended to indicate when dirty filters should be changed, this should be installed internally, as shown below. For further information regarding fitted controls, please see the accompanying controls O&M.



Filter pressure switch on Max unit (side view)

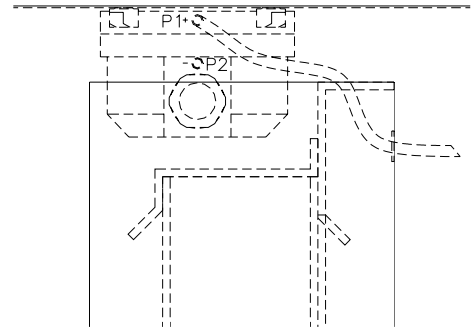

Filter pressure switch detail (plan view)

Maintenance Filter removal

Caution When accessing the unit ensure the access panels are handled/opened in a controlled manner so as to avoid damage to the unit or injury to personnel. This is particularly important with bottom access units.

Slide in To replace a contaminated slide in panel filter, access to the filter section is gained by the marked service panel or access door. To remove the panel filter from the bulkhead, rotate the filter fixing plate as shown below, the current panel filter cassette can then be withdrawn along the filter support rails. Contaminated filters should be replaced making sure they are fitted tightly into the section casework. Ensure pleats are vertical when replacing the panel section. Ensure all components are secured back into position once reinstalled, using the filter fixing plates.

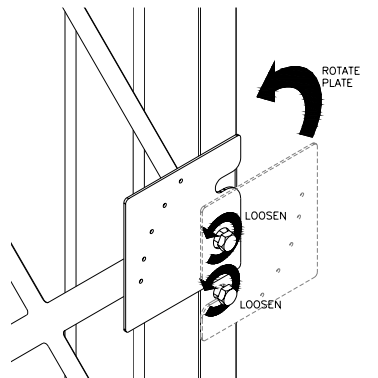

Filter panel fixing plate

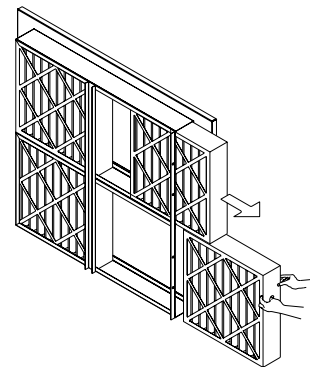

Filter withdrawal



Installation, Operation and Maintenance Manual

Panel Filters

Maintenance Continued Clip in

To replace a contaminated clip in panel filter, access to the filter section is gained by the marked service panel or access door.

To remove the panel filter from the bulkhead, rotate the filter clips as shown below, then remove the current panel filter cassette from the bulkhead.

Contaminated filters should be replaced making sure they are fitted tightly into the section casework. Ensure pleats are vertical when replacing the panel section.

Ensure all components are secured back into position once reinstalled, using the filter fixing plates.

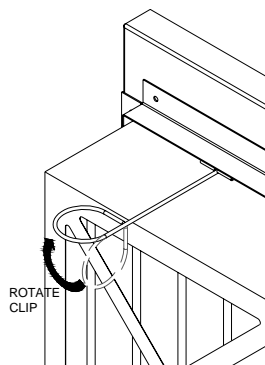

Filter clip rotation

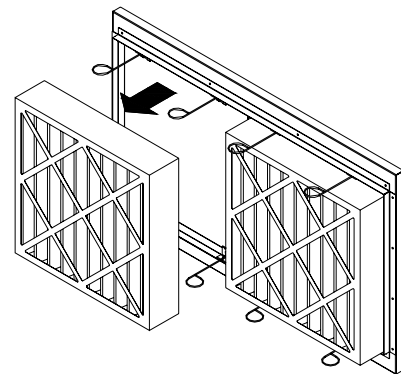

Clip in panel filter withdrawal

Recommended Checks

To keep the unit in good working order the following maintenance routine is recommended.

Filters should be inspected every three months. If they are found to be heavily damaged or soiled in any way they should be replaced.

In general, this series of units require little maintenance. In the unlikely event of component failure, spares are available from VES Andover Ltd.

Important  Before attempting to carry out any work on our units, all accompanying documentation including warning labels on the unit must be referenced. Should it be necessary to remove any components ensure that these are secured into position once reinstalled. It is critical that after any maintenance work has been conducted that all components removed/replaced be refitted correctly by a competent engineer.

Warning  Before attempting to carry out any maintenance, investigative or repair work on our units, the unit **MUST BE COMPLETELY ISOLATED** from its electrical supply. Ensure a minimum of two minutes after electrical disconnection before removing access panels.

Caution  Ensure the unit has been allowed to completely cool before attempting any work to the unit.



Installation, Operation and Maintenance Manual

Panel Filters

Maintenance Continued Recommended Checks

Should a full service be required it may be necessary to disassemble the unit casework to gain access to some components.

Important



Should it be necessary to remove any slide-in components ensure that these are secured into position once reinstalled. It is critical that after any maintenance work has been conducted that all components removed/replaced be refitted correctly by a competent engineer.

Sufficient clearance should be provided to enable the filter to be withdrawn from the casework, for confirmation of required access please refer to the appropriate outline drawing; note some access doors are hinged.

Spares & Repairs

When enquiring after or ordering spares contact VES Andover Ltd. Spares Department, quoting the sales order (SO) number and unit type as found on the unit name plate.

Tel: 08448 15 60 60

Fax: 02380 26 12 04

WEEE Directive



At the end of their useful life the packaging and product should be disposed of via a suitable recycling centre. Do not dispose of with normal household waste. Do not burn.



PLEASE ENSURE THIS DOCUMENT IS PASSED ON TO THE END USER

We reserve the right to alter the specification without notice © VES Andover Ltd. 2012.
No part of this publication may be photocopied or otherwise reproduced without prior permission in writing of VES Andover Ltd.



Installation, Operation and Maintenance Manual

Heat Wheels

Please refer to the accompanying Suppliers O&M Manual for this component.

Check for possible damage in transit. In the event of any damage having occurred or if an item is found to be missing, it is essential to inform VES Andover Ltd. within **7 working days** of delivery, quoting the sales order number and the unit type, as found on the unit name plate.

After this period, VES Andover Ltd. will be unable to accept any claim for damaged or missing goods.

Before attempting to carry out any work on our units, all accompanying documentation including warning labels on the unit must be referenced. Should it be necessary to remove any components ensure that these are secured into position once reinstalled. It is critical that after any maintenance work has been conducted that all components removed/replaced be refitted correctly by a competent engineer.

When enquiring after or ordering spares contact VES Andover Ltd. Spares Department, quoting the sales order (SO) number and unit type as found on the unit name plate.

If the relevant documentation for the component is missing please contact the Design Department for replacements quoting the sales order (SO) number and unit type as found on the unit name plate.

Tel: 08448 15 60 60

Fax: 02380 26 12 04



max[®] Air Handling Unit

Installation, Operation and Maintenance Manual

Plug fans

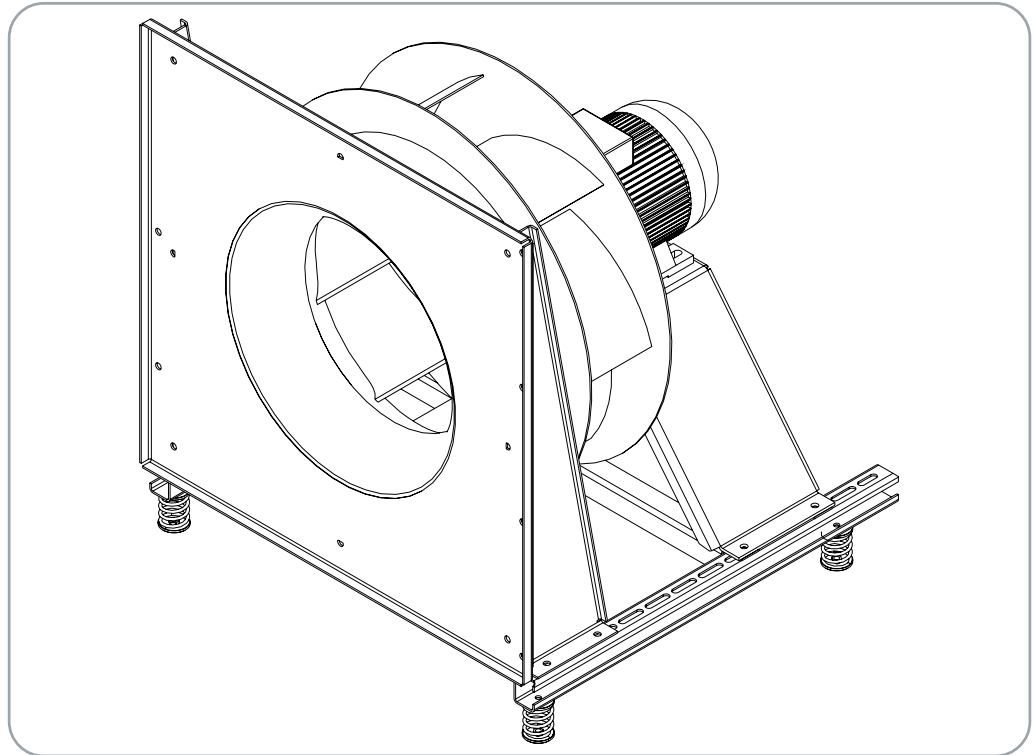

Plug fan

Introduction

Plug fans are the latest generation of Energy Efficient backward curved single inlet centrifugal fans with fitted motor. For confirmation of the motor, Kw rating and design running frequency of the fan fitted in this unit please refer to the unit outline drawings.

Receipt of Goods & Handling

Check for possible damage in transit paying particular attention to fan impellers and motor. Prior to installation please check to ensure alignment and smooth rotation of the impeller after transit.

In the event of any damage having occurred or if an item is found to be missing, it is essential to inform VES Andover Ltd. within **7 working days** of delivery, quoting the sales order number and the unit type, as found on the unit name plate.

After this period, VES Andover Ltd. will be unable to accept any claim for damaged or missing goods.

Installation

Caution



Operation of the fan outside of its intended application and technical specifications, (as shown on the fan/impeller rating plate) can lead to defect or damage within the device. The fans are only intended for the conveyance of air or mixtures similar to air. Damages resulting from use outside of those intended will be classed as unauthorised and will not be the liability of VES Andover Ltd. The user will assume sole responsibility.



max Air Handling Unit
bespoke

Installation, Operation and Maintenance Manual

Plug fans

Installation Continued

Motor and electrical details must be checked prior to connection to mains supply. All motor information can be found on the unit data sheet, supplied attached to the unit. Units with direct drive fans should be subject to a check that the impeller blades are not damaged and spin freely.

Motor bearings should be inspected to ensure their proper operation prior to installation. Damage to the bearings can be caused if the fan remains stopped in a moist environment.

For safety reasons, fans should not be modified without authorisation, any planned modifications must be authorised by VES Andover Ltd. in writing, as unauthorised changes may effect the terms of any warranty held with VES Andover Ltd.

Only parts specifically designed for the fan supplied and recommended by VES Andover Ltd. should be used, non-genuine parts, or parts from non-original sources are not guaranteed to meet load and safety requirements set out by the original manufacturer. Such parts are not approved by VES Andover Ltd. and the use of such parts may effect the terms of any warranty held with VES Andover Ltd.

The fan itself may only be lifted using a suitable hoisting device and spreader, the lifting beam needs to be positioned transverse to the motor axis.

Wiring

Warning  The electrical supply **must be fully isolated** before attempting any work on this unit. All electrical connections to any unit must be carried out in accordance with the current edition of the **I.E.E Regulations**. Only competent electricians should be allowed to affect any electrical work to our units.

Important  It is the customer's responsibility to supply earth fault protection through the buildings installation device and a dedicated, isolated power supply with overload protection, to account for motor start up currents. See the accompanying fan wiring diagram for specific fan details.

Warning  Do not connect any unit to an electrical supply voltage outside of the specification.

If in any doubt, consult the wiring diagram in your document pack or contact VES Andover Ltd. Customer Services Department on **08448 15 60 60**, quoting the sales order (SO) number and unit type as found on the unit name plate.

For Three Phase Fans, a trial connection of the three phase supply should be made to check that the fans rotates in the correct direction indicated on the fan. If the rotation is incorrect, interchange any two phases of the incoming supply at the terminal block. For incorrect rotation of single phase fans, check with the VES Andover Ltd. Service Department for advice, on **08448 15 60 60**.

Warning  It is essential that all electrical connections are properly made.

Important  Pre-wired units supplied in sections may require a number of wires to be reconnected to either the isolator/control panel or, in the case of multiple sections, a local terminal box. For further information regarding fitted controls, please see the accompanying controls O&M.



max Air Handling Unit
bespoke

Installation, Operation and Maintenance Manual

Plug fans

Installation Continued Set up

Prior to starting the unit it is important to ensure that the fans are free running. All leftover installation material and other foreign material should be removed from the fan section.

Should any components have moved during transit take care to ensure they are realigned to allow correct operation/rotation. The same should be applied to any wiring looms which may have become unfastened; ensure that loose wiring is securely stowed away from any moving components.

All electrical connections should be checked to ensure they have been properly made.

A check for mechanical vibration should be made after installation, quiet, low vibration during operation is desirable. Strong vibrations due to erratic operation can be caused by transportation damage or improper use and can lead to failure. If necessary rebalancing may be required by a specialist.

Inverter-driven plug fans are supplied as a balanced assembly and should not be disassembled, however the assembly is secured for transit with bolts as shown; these should be removed prior to start-up.

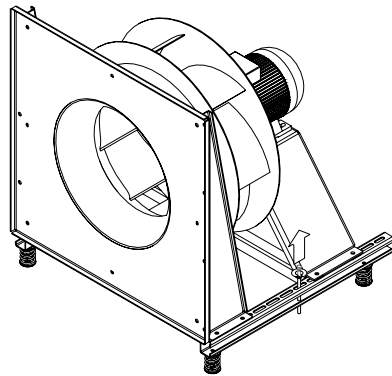

Typical plug fan set up showing necessary transit bolt removal

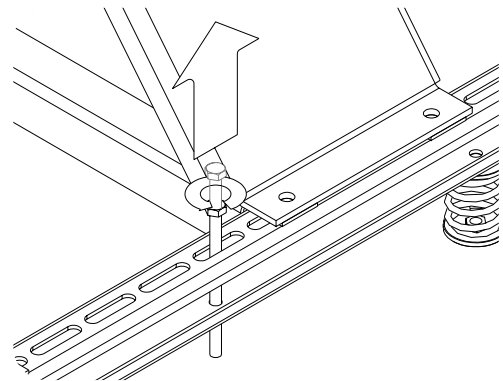

Transit bolt removal detail

Only operate the fan up to the maximum permissible speed as given on the fan/impeller rating plate. Exceeding this speed can lead to a high kinetic energy and a resulting hazardous situation.

Caution  Faulty components, incorrect adjustments and bad electrical connections to the fan during installation can cause unexpected and hazardous conditions during commissioning.



Installation, Operation and Maintenance Manual

Plug fans

Installation Continued Speed controllers

Units with speed controllers should also be considered during installation, it should be ensured that the maximum permissible speed can not be exceeded due to a malfunction of the frequency converter.

Suitable speed controllers without on/off switches are available from VES Andover Ltd. For commissioning; see the accompanying controls O&M for further operational details.

Control systems

A suitable control system should be provided and should include a timer to keep the fan running for 2 minutes after the heater has been shut off. The standard VES Andover Ltd. control panels are designed for easy operation and connection.

Max units may be supplied with fitted 3 phase inverters for fan speed control and commissioning; see the accompanying controls O&M for further operational details. The centrifugal plug fans have infinite adjustment and when controlled by inverter, the benefits of real energy savings are apparent when the fan speed is reduced; this is best demonstrated when used in conjunction with additional sensors such as air quality or occupancy.

Using a micro manometer and adjusting the fan speed via the inverter it is possible to commission each fan to the required air volume. Each fan section has a differential pressure tapping connection point; by connecting your micro manometer to the appropriate Pitot a differential pressure reading can be taken.

For further information regarding fitted controls, please see the accompanying controls O&M.

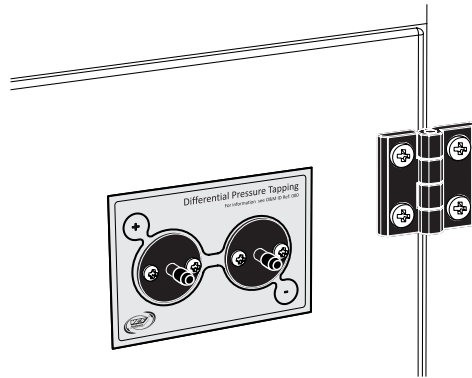

Differential pressure tapping point

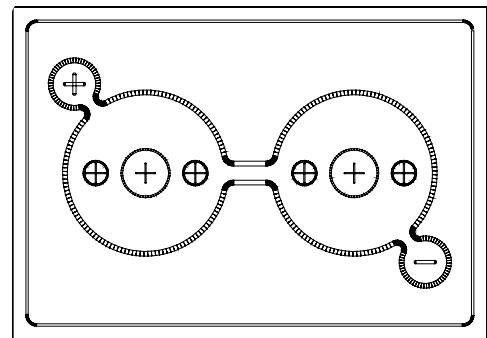

Differential pressure tapping point detail

Installation, Operation and Maintenance Manual

Plug fans

Installation Continued Control systems

This differential pressure compares the static pressure in front of the fan inlet ring with the static pressure in the inlet ring of the narrowest point.

The differential pressure between the static pressures is related to the air volume via the energy conservation rate as per the graph below.

Simply read across from the pressure measurement to the appropriate fan curve and down to calculate the resultant air volume.

For example: Measured differential pressure: 1400Pa
 Unit: ER40C
 Reading from graph: 1.6
 Air Volume: 1.6 m³/s

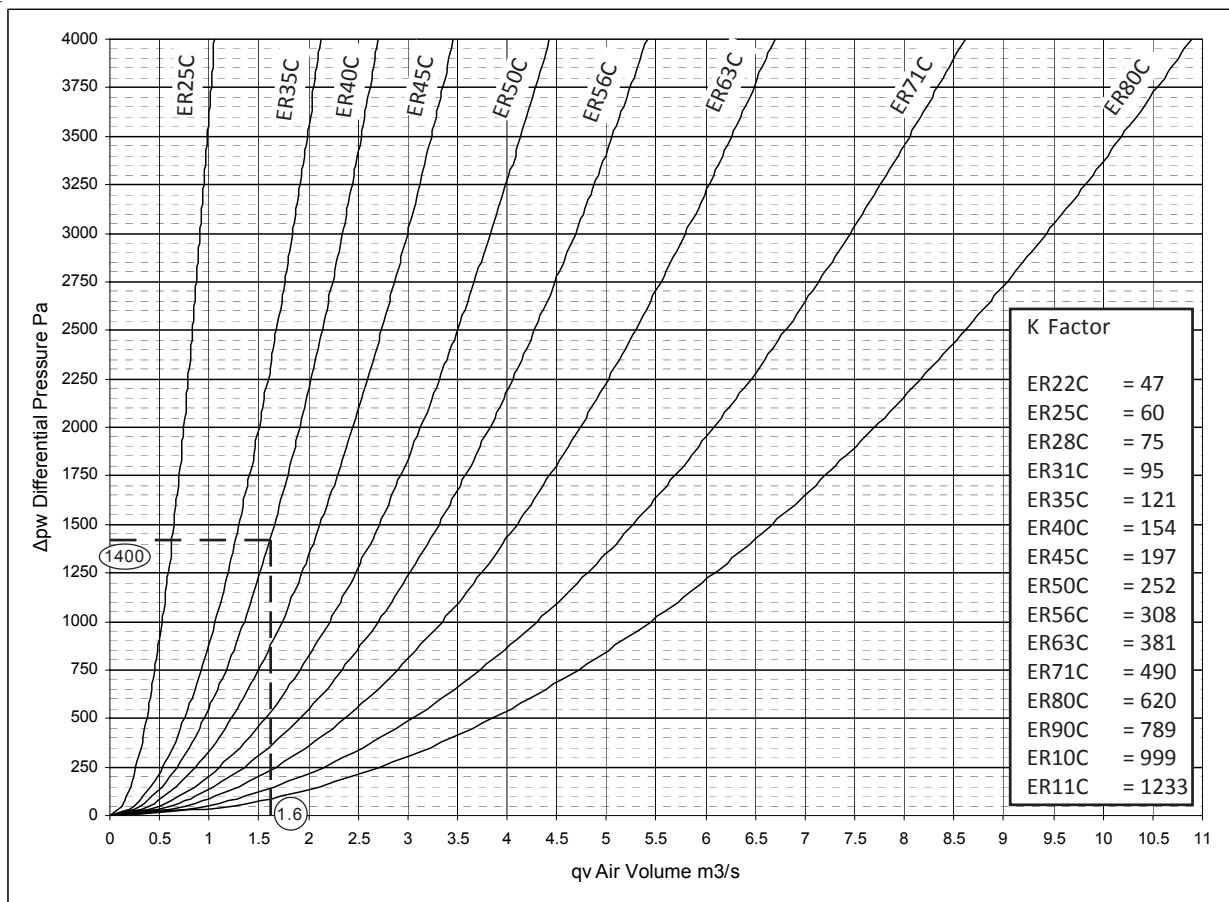

Differential pressure commissioning graph

Installation, Operation and Maintenance Manual

Plug fans

Installation Continued Control systems

This measurement can also be expressed in the following calculation:

$$q_v = (k\sqrt{\Delta p_w}) / 3600$$

Where q_v is the air volume in m³/s

k is the fan nozzle coefficient

Δp_w is the measured differential pressure in Pa

For example: Measured differential pressure: 550Pa

Unit: ER40C

$$q_v = (154 \sqrt{1400}) / 3600$$

$$q_v = (154 \times 37.417) / 3600$$

$$q_v = 5762 / 3600$$

$$q_v = \text{air volume} = 1.6 \text{ m}^3/\text{s}$$

Operation

Warning  Faults detected within any electrical equipment must be rectified as soon as possible. If faults are not resolved the fan becomes potentially hazardous, the fan should not be operated when faulty.

The end user is obliged to ensure:-

- That the fan operated is in good working order.
- That the fan is used only as intended.
- That periodical examination of the unit, all its parts and any safety equipment takes place.
- That all safety and warning labels attached to the unit and its parts are not removed and always remain legible.
- That the fan is not operated in an explosive atmosphere.
- That all motor manufacturer's instructions are observed.



max Air Handling Unit
bespoke

Installation, Operation and Maintenance Manual

Plug fans

Maintenance

Recommended Checks

Caution  Ensure the unit has been allowed to completely cool before attempting any work to the unit.

To keep the unit in good working order the following maintenance routine is recommended.

Every three months the general operation of the unit should be inspected, particularly for noise from bearings, motors and fans. An irregular noise could signify that unit failure is imminent.

Every six months check for dust build-up in the system, especially around the impeller. Remove dust if necessary. Failure to do this periodically could lead to a loss of performance or cause the fan to become out of balance, ultimately leading to bearing failure.

Every twelve months the fan should be checked for mechanical oscillations the maximum severity of vibration permitted is 2.8mm/s.

Fan frames are supplied with either unpainted galvanized sheet steel or powder coat paint finishes. Check all painted items to ensure that they have not deteriorated. Repaint as necessary. Paint can be supplied upon request. Checks should also be carried out for missing fasteners.

In general, this series of units require little maintenance. In the unlikely event of component failure, spares are available from VES Andover Ltd.

Should a full service be required it may be necessary to disassemble the unit casework to gain access to some components.

Important  Before attempting to carry out any work on our units, all accompanying documentation including warning labels on the unit must be referenced. Should it be necessary to remove any components ensure that these are secured into position once reinstalled. It is critical that after any maintenance work has been conducted that all components removed/replaced be refitted correctly by a competent engineer.

Warning  Before attempting to carry out any maintenance, investigative or repair work on our units, the unit **MUST BE COMPLETELY ISOLATED** from its electrical supply. Ensure a minimum of three minutes after electrical disconnection before removing access panels.

The fan/motor may switch on and off automatically for functional reasons.

After a power outage and subsequent voltage return the fan will complete an automatic restart.





max[®] Air Handling Unit

Installation, Operation and Maintenance Manual

Plug fans

Maintenance Continued Recommended Checks

Caution  When accessing the unit ensure the access panels are handled/opened in a controlled manner so as to avoid damage to the unit or injury to personnel. This is particularly important with bottom access units.

Important  Should it be necessary to remove any slide-in components ensure that these are secured into position once reinstalled. It is critical that after any maintenance work has been conducted that all components removed/replaced be refitted correctly by a competent engineer.

Sufficient clearance should be provided to enable access to the unit casework, for confirmation of required access please refer to the appropriate outline drawing; note some access doors are hinged.

Cleaning Regular inspection, and cleaning is necessary to prevent imbalance due to build up of dirt.

Before cleaning the fan with water, note the fans IP protection class and follow the recommended cleaning methods. Make sure no water gets inside of the motor and electronics, if water enters the motor dry off the motor winding before using it again.

The entire fan can be cleaned, the fans flow area should also be cleaned. Maintenance of the fan depends upon the level of contamination on the impeller.

Do not use aggressive, paint solvent cleaning agents when cleaning.

Warning  Maintenance and cleaning of the fans whilst running is not permitted and can lead to an electric shock, danger of death.

Spares & Repairs When enquiring about, or ordering spares contact VES Andover Ltd. Spares Department, quoting the sales order (SO) number and unit type as found on the unit name plate.

Tel: 08448 15 60 60

Fax: 02380 26 12 04

WEEE Directive  At the end of their useful life the packaging and product should be disposed of via a suitable recycling centre. Do not dispose of with normal household waste. Do not burn.



PLEASE ENSURE THIS DOCUMENT IS PASSED ON TO THE END USER

We reserve the right to alter the specification without notice © VES Andover Ltd. 2012.
No part of this publication may be photocopied or otherwise reproduced without prior permission in writing of VES Andover Ltd.



max Air Handling Unit

Installation, Operation and Maintenance Manual

Hot water LPHW coil

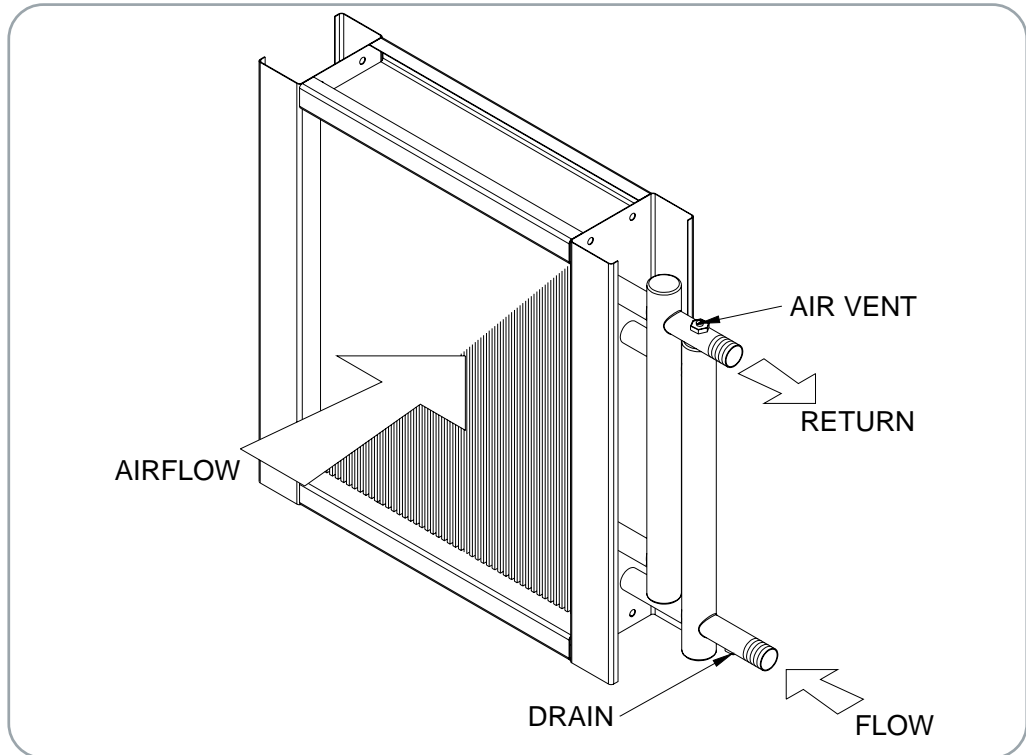

LPHW Coil diagram

Introduction

This Max unit has been fitted with a Low Pressure Hot Water (LPHW) coil. This coil is normally suitable for LPHW at 82°C flow and 71°C return temperature. LPHW coils are supplied as standard with an air vent and drain plug located on the pipe work connections. The air vent is on top of the top connection and the drain is on the underside of the bottom connection. The coil should be regularly vented so as to avoid potential air locks, resulting in a fall off of duty. It is recommended that a check be made as to whether any treatment is required to the water supply for prevention of corrosion and scaling of the equipment. Information regarding necessary action to be taken can be obtained from the relevant Local Water Supply Authority.

Caution  The coil must be purged of air before the unit is operated for the first time. An air purging valve must be fitted to the outlet connection.

Receipt of Goods & Handling

Check for possible damage in transit paying particular attention to coil connections. In the event of any damage having occurred or if an item is found to be missing, it is essential to inform VES Andover Ltd. within **7 working days** of delivery, quoting the sales order number and the unit type, as found on the unit name plate. After this period, VES Andover Ltd. will be unable to accept any claim for damaged or missing goods.

Installation, Operation and Maintenance Manual

Hot water LPHW coil

Installation

Coils should be piped according to any relevant local codes of practice. Where threaded connections are supplied, the only approved method of jointing is by use of boss white and hemp. The coil must be installed with the circuit tubing horizontal to enable venting and drainage. Ensure that the connected piping does not obstruct access to the other sections in the unit. The thread fitted to the coil is to be supported at all times whilst making joints. Check that the deadweight and expansion forces of the piping are not applied to the liquid connections. All external piping is to be supported independently from the coil. Fluid filters are recommended.

The unit will have been supplied with connections either left or right hand side looking in the direction of airflow. Please see order acknowledgment or outline drawing for confirmation of this handing. Should you need to alter this please consult VES Andover Ltd. as unit adjustment may invalidate your warranty.



Caution Heating coils do not cool immediately when the hot water supply is cut off.

The residual heat must be dissipated to avoid damage. The continuous running of the fan after shutdown resolves this, by operation of a run-on timer. The recommended length of run-on is **2 minutes minimum**.

It is important that water coils are protected against damage from extreme weather conditions during the winter season. If the water is allowed to freeze in the coil system, damage may occur potentially bursting pipes and resulting in emergency problems. Fitting a frost thermostat at the unit inlet and ensuring that boilers run continuously in low ambient temperatures can help prevent this.

It is recommended that a frost thermostat be fitted within the heater coil compartment to help protect the coil against extreme weather conditions. The frost thermostat should be fitted in the most accessible location within the coil section i.e. near to a door or access panel. The temperature probe is then secured within the heating coil fins on the "air off" side of the coil.

The temperature controller wheel should be set to 5°C. Refer to the wiring diagram below for connections to a control panel etc.

If in doubt contact VES Andover Ltd. Customer Services Department quoting the sales order number and the unit type, as found on the unit name plate.

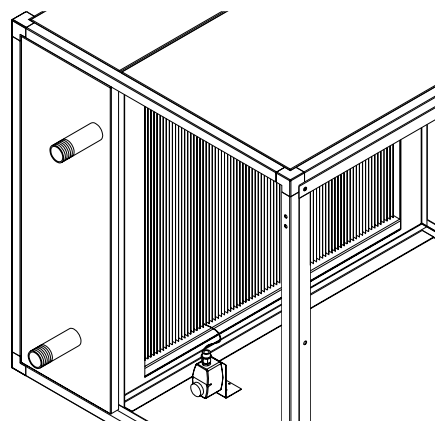

LPHW Coil with fitted frost thermostat

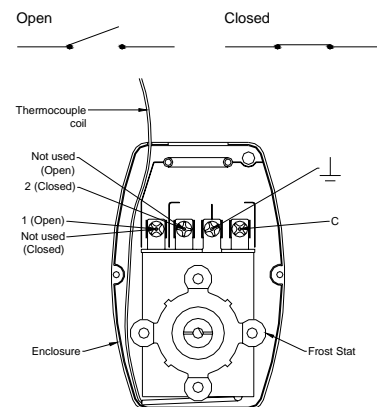

Frost thermostat wiring diagram



Installation, Operation and Maintenance Manual

Hot water LPHW coil

Maintenance Recommended Checks

To keep the unit in good working order the following maintenance routine is recommended.

Coils should be inspected every six months to ascertain if any foreign matter has accumulated between the fins. Also that the coil connections are free from any leaks. Should any matter be found, the coils should be cleaned using a soft brush coil comb, vacuum cleaner or a water hose and mild solution of commercial detergent. If heavily contaminated a steam lance may be used.

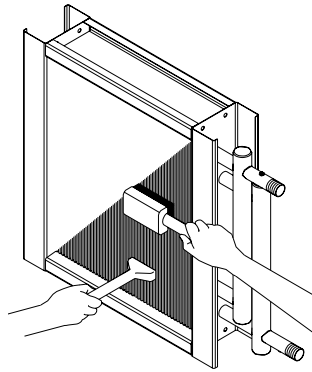

Cleaning the coil with a soft brush, coil comb or a vacuum cleaner

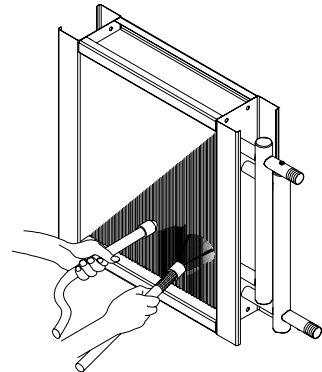

Cleaning the coil with a steam lance or water hose and detergent solution

Coils should be inspected for signs of corrosion and breakdown of surface treatment where applicable. Circulating fluid should be kept free from impurities and corrosive elements. Check all connections and tighten if necessary. Check the coil for any minor fin damage and use a fin comb to reinstate any damaged fins.

Important



Care should be taken so as not to damage or distort the fins during this cleaning process. Always brush with the direction of the fins, not across the fins.

Coils should be inspected for signs of corrosion and breakdown of surface treatment where applicable.

In general, this series of units require little maintenance. In the unlikely event of component failure, spares are available from VES Andover Ltd.

Important



Before attempting to carry out any work on our units, all accompanying documentation including warning labels on the unit must be referenced. Should it be necessary to remove any component ensure that these are secured into position once reinstalled. It is critical that after any maintenance work has been conducted that all components removed/replaced be refitted correctly by a competent engineer.

Warning



Before attempting to carry out any maintenance, investigative or repair work on our units, the unit **MUST BE COMPLETELY ISOLATED** from its electrical supply. Ensure a minimum of two minutes after electrical disconnection before removing access panels.

Caution



Ensure the unit has been allowed to completely cool before attempting any work to the unit.



max Air Handling Unit
bespoke

Installation, Operation and Maintenance Manual

Hot water LPHW coil

Maintenance Continued

Should a full service be required it may be necessary to disassemble the unit casework to gain access to some components.

Caution  When accessing the unit ensure the access panels are handled/opened in a controlled manner so as to avoid damage to the unit or injury to personnel. This is particularly important with bottom access units.

Important  Should it be necessary to remove any slide-in components ensure that these are secured into position once reinstalled. It is critical that after any maintenance work has been conducted that all components removed/replaced be refitted correctly by a competent engineer.

Sufficient clearance should be provided to enable the coil to be withdrawn from the casework, for confirmation of required access please refer to the appropriate outline drawing; note some access doors are hinged.

Spares & Repairs

When enquiring about, or ordering spares contact VES Andover Ltd. Spares Department, quoting the sales order (SO) number and unit type as found on the unit name plate.

Tel: 08448 15 60 60

Fax: 02380 26 12 04

WEEE Directive



At the end of their useful life the packaging and product should be disposed of via a suitable recycling centre. Do not dispose of with normal household waste. Do not burn.



PLEASE ENSURE THIS DOCUMENT IS PASSED ON TO THE END USER

We reserve the right to alter the specification without notice © VES Andover Ltd. 2012.
No part of this publication may be photocopied or otherwise reproduced without prior permission in writing of VES Andover Ltd.



Installation, Operation and Maintenance Manual

Warranty

General

All VES Andover Products come with a one-year guarantee from the date of dispatch, which covers parts and labour.

To extend your warranty VES can offer you a maintenance agreement that keeps this equipment in tip-top condition.

If you take out this agreement, we will extend the warranty **free of charge for up to 5 years**, providing the regular maintenance agreement remains in place.

For a quotation or more information on this service please contact our **Specialist Site Services Department on +44 (0) 8448 15 60 60 Ext: 639** or simply email all your details to sssales@ves.co.uk

For all spares enquiries and ordering of parts please contact our **Specialist Spare Parts team on 08448 15 60 60 Ext: 643** quoting your unique VES serial number or simply email spares@ves.co.uk

To ensure a prompt efficient response when emailing please provide company details, telephone number and description of requirements.

VES spares also offer a separate free spares reminders scheme for filter change:

This scheme can help ensure your equipment is kept in optimum condition. If you would like to subscribe to this service, please contact us on the spares line above.

Once subscribed you will be eligible to a 5% regular user discount on your replacement filter prices and a fixed £20.00 carriage charge for all UK Main Land deliveries.

To arrange any of these options

Phone: [+44 \(0\)8448 15 60 60](tel:+44(0)8448156060)

or Email: spares@ves.co.uk

Stating the sales order and reference number from the unit.



BlueSense philosophy combines intelligent control technologies with energy saving products, services and engineering expertise. BlueSense helps meet energy reduction commitments by optimising the equipment performance, improving energy efficiency, saving money and increasing equipment life expectancy.

BlueSense can be applied to a variety of projects and applications, providing efficient solutions whilst supporting design for best practice and sustainability.

BlueSense includes an extended warranty.

- 3 Years with BlueSense packages.
- 5 Years with BlueSense package and Post Installation Commissioning.

Please quote BlueSense with your order or contact our specialist sales team for further information. **Call +44 (0)8448 15 60 60 or Email info@ves.co.uk**



Installation, Operation and Maintenance Manual



Declaration of Conformity

Date: 04th May 2012
Product: Max Air Handling Units
Type: Max Units
Manufacturer: VES Andover Limited

The product above is produced in accordance with EC Council Directives:

2004/108/EC (Electromagnetic Compatibility Directive)

2006/95/EC (Low Voltage Directive)

2006/42/EC (Machinery Directive)

The European Harmonised Standards applied are:

BS EN ISO 12100, BS EN ISO 13857:2008, EN61000, EN60204-1, EN 60950-1:2002

Basis of Self attestation:

Quality Assurance to ISO 9001-2000, BSI Reg. Firm Cert. No. Q5375

Signature of Manufacturer:



Position of Signatory:

Director